

3-tier square glass merchandiser, offers pioneering heating technology designed to deliver the perfect pie. Compliance to food-safe temperature zones. Suited to any heated food departments.

Linear Pie Warmer

BA1085

*New Improved
S-H Heating Technology*

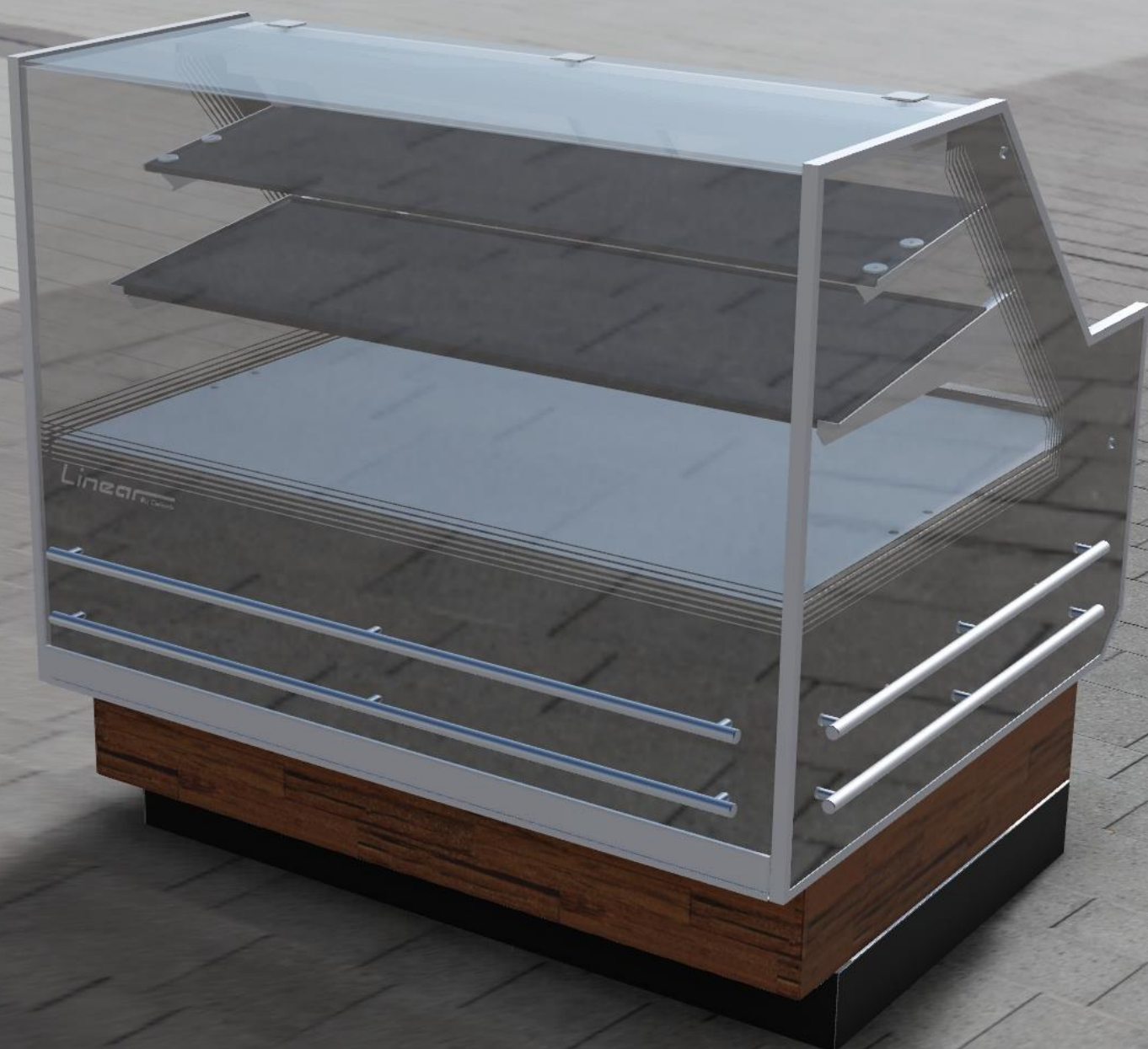
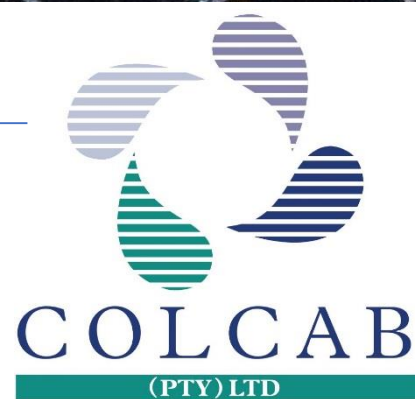

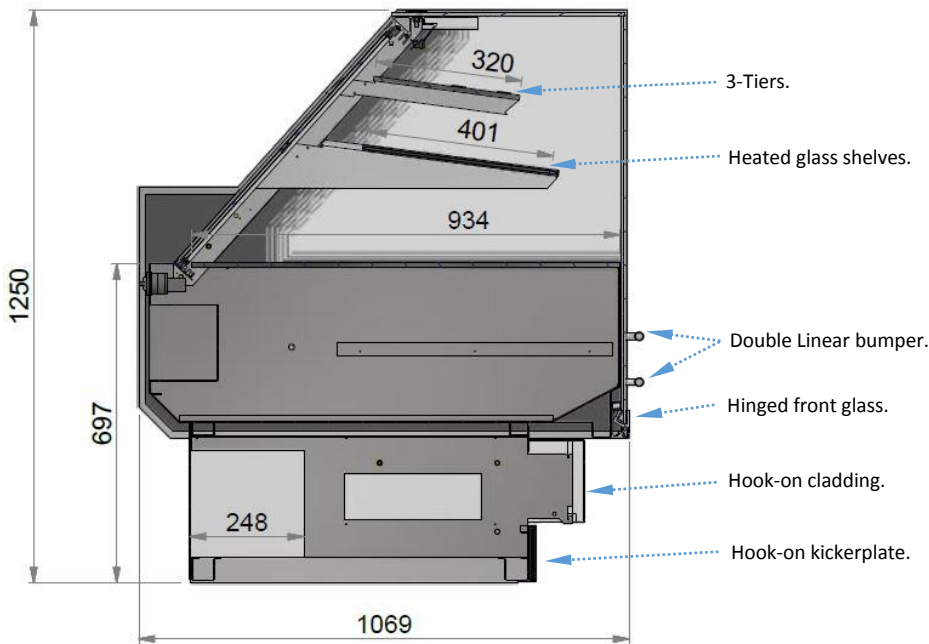

Please consult COLCAB Technical Spec Reference Manual for dimensions, plan views and technical specifications. Specifications subject to change without notice. Designed for optimal performance in store environments where temperature and humidity do not exceed 25°C and 60% R.H.

S - H HEATING TECHNOLOGY

Energy Options:

- Heated glass shelves.
- 30% reduction in energy due to S-H heating technology.
- LED lights - 4000k natural white.

Standard Options:

- Available in lengths 4', 6' lengths.
- Configured with a variety of front panel design options including wood, glass, stainless steel or aluminium Linear bumpers.
- Configured with integrated glass patch ends.
- Available with aluminium or stainless steel trays.
- Rear storage shelves.
- Remote or self-contained options.
- Removable rear sliding close-offs.
- Independently heated glass shelves.

Features and Benefits:

- Unique design ensures uniform case performance and lower average product temperatures with optimum energy efficiency.
- All-steel and powder-coated construction for increased life span and structural integrity.
- On-trend design and feature will compliment both modern and contemporary store environments.
- 3-Way silk screen-printed glass offers enhanced product visibility and panoramic vista.
- High quality stainless steel or aluminium double bumper system delivers practical, aesthetic and unparalleled protection and durability.
- NEW S-H heating technology offers both consistency and accuracy for control of food-safe temperature zone.
- Frameless glass construction.
- Easy on / off kickplate and cladding.



COLCAB
(PTY) LTD

OPTIMISING DISPLAY EXCELLENCE

POSTAL: P.O.Box 123 • Blackheath • 7580
T: +27 (0)21 907 2800 • F: +27 (0) 907 2850
www.colcab.co.za • www.colcab.co.za/mobile