

Variable bowl combinations, served / self-service glazed canopy salad valley merchandiser, offers blue-sky food-safe environment with enhanced product appeal. Suited to mid-floor fixed / impulse location at produce, deli and whole food departments.

## Rectangular Salad Merchandiser

# B4202

*Self-Contained / Remote Option  
Rectangular Salad Merchandiser*



**COLCAB**  
(PTY) LTD



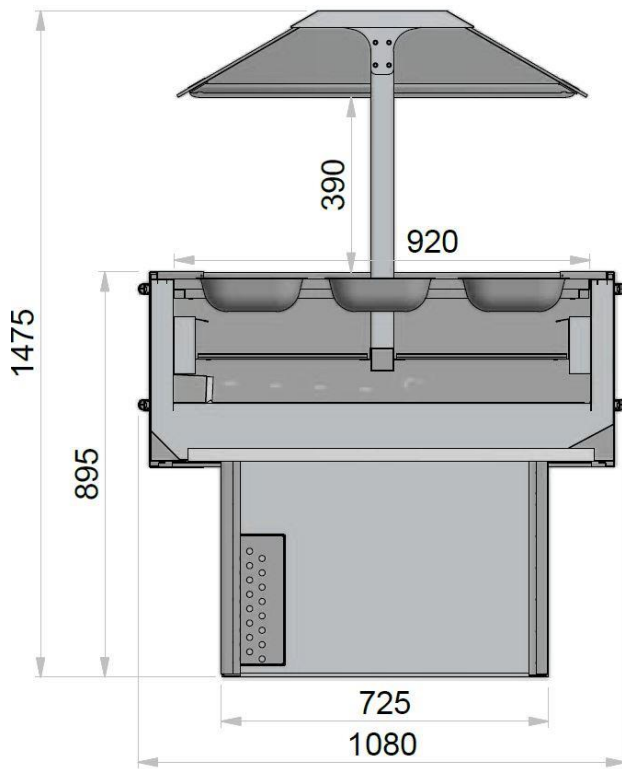

RECTANGULAR SALAD MERCHANDISER

Please consult COLCAB Technical Spec Reference Manual for dimensions, plan views and technical specifications. Specifications subject to change without notice. Designed for optimal performance in store environments where temperature and humidity do not exceed 25°C and 60% R.H.

### Energy Options:

- ECM fans.
- EEV – electronic expansion valves.
- LED lights - 4000k natural white.
- Butcher option LED lights available.

### Standard Options:

- Available in 6', 8', 12' lengths.
- Remote or self-contained option.
- Optional Corian or Granite work tops.
- Flat 14 salad bowl insert.
- Flat 10 half bowl insert.
- Step 12 salad bowl insert.
- Sloped gourmet insert.

### Features and Benefits:

- Unique design ensures uniform case performance and lower average product temperatures with optimum energy efficiency.
- All-steel and powder-coated construction for increased life span and structural integrity.
- Stainless steel used for all fish and meat produce.
- Seamless tub liner provides positive drain run-off and enhanced sanitation.
- Glass canopy – sneeze guard offers high visibility blue-sky LED lighting.
- Variable bowl combinations suited to serves or self-service applications.
- Low noise emitting compressor and fans.



**COLCAB**  
(PTY) LTD

OPTIMISING DISPLAY EXCELLENCE

POSTAL: P.O.Box 123 • Blackheath • 7580

T: +27 (0)21 907 2800 • F: +27 (0) 907 2850

www.colcab.co.za • www.colcab.co.za/mobile