

Modern square glass style 2-tier merchandiser, offers pioneering heating technology designed to deliver the perfect pie. Compliance to food-safe temperature zones. Suited to any heated food departments.

SQ Pie Warmer

BA0512

*New Improved
Square Pie Warmer*



COLCAB
(PTY) LTD



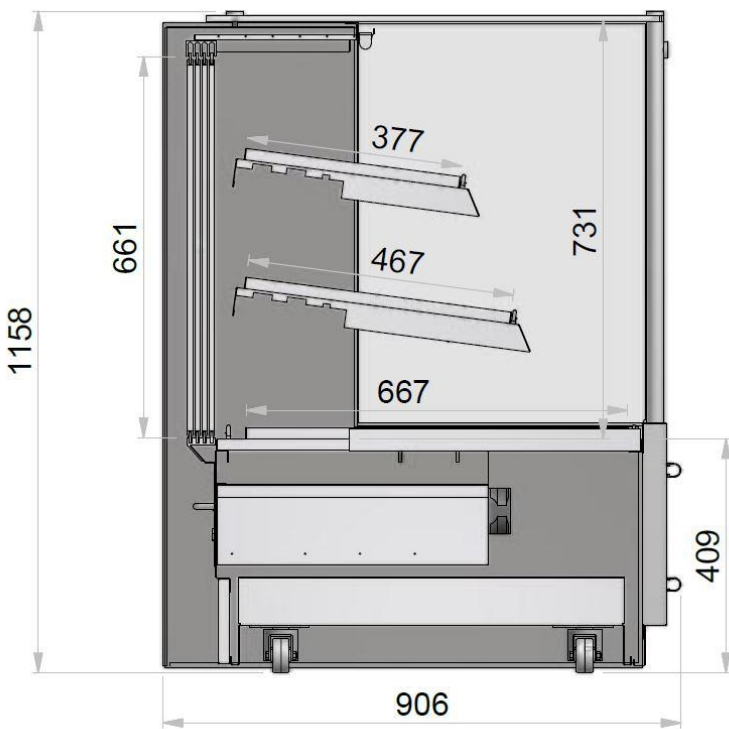

S - H HEATING TECHNOLOGY

Please consult COLCAB Technical Spec Reference Manual for dimensions, plan views and technical specifications. Specifications subject to change without notice. Designed for optimal performance in store environments where temperature and humidity do not exceed 25°C and 60% R.H.

Energy Options:

- 30% reduction in energy due to S-H heating technology.
- LED lights - 4000k natural white.

Standard Options:

- Available in 4', 6', 8', 12' lengths.
- Configured with a variety of front panel design options including wood, glass, stainless steel or aluminium Linear bumpers.
- Configured with integrated glass patch ends.
- Available with aluminium or stainless steel trays.
- Removable rear sliding close-offs.
- Independently heated shelves.

Features and Benefits:

- Unique design ensures uniform case performance, consistent heat control and average product temperatures with optimum energy efficiency.
- All-steel and powder-coated construction for increased life span and structural integrity.
- On-trend design and features will compliment both contemporary and modern store environments.
- High quality stainless steel or aluminium double bumper system delivers practical, aesthetic and unparalleled protection and durability.
- NEW S-H heating technology offers both consistency and accuracy for control of food-safe temperature zone.
- Rear sliders offer easy access to all shelves.
- Wheeled mobility offers easy relocation and cleaning.
- Plug and play.



COLCAB
(PTY) LTD

OPTIMISING DISPLAY EXCELLENCE

POSTAL: P.O.Box 123 • Blackheath • 7580
T: +27 (0)21 907 2800 • F: +27 (0) 907 2850

www.colcab.co.za • www.colcab.co.za/mobile